

Remove concrete for driveway construction where required.

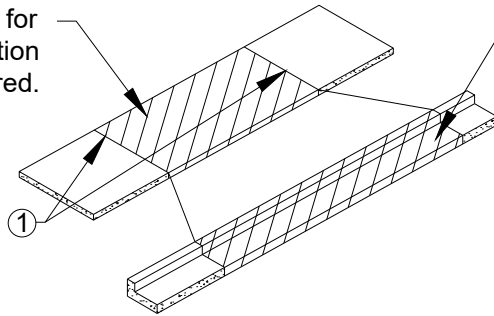

Remove curb and gutter. Entire curb and gutter section shall be removed prior to driveway construction

REMOVALS

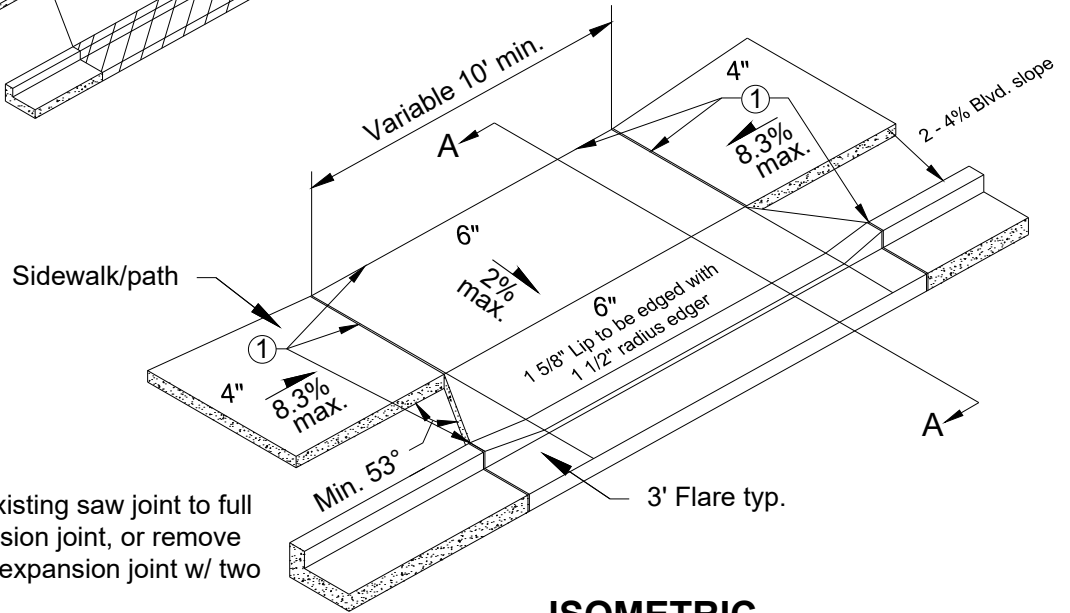

Notes:

1. Where connecting to existing saw joint to full depth and install expansion joint, or remove and replace to nearest expansion joint w/ two $\frac{1}{2}$ " x 24" smooth dowels.
2. Driveways greater than 10' wide shall have contraction joints perpendicular to curb with minimum 10' spacing. Match curb joints.
3. Forms are required on all edges.
4. All HMA patches shall be done with NDDOT FAA 43 HMA pavement, PG 58S-28.
5. Max. cross-slope of sidewalk/path shall be 2% at all locations.

ISOMETRIC

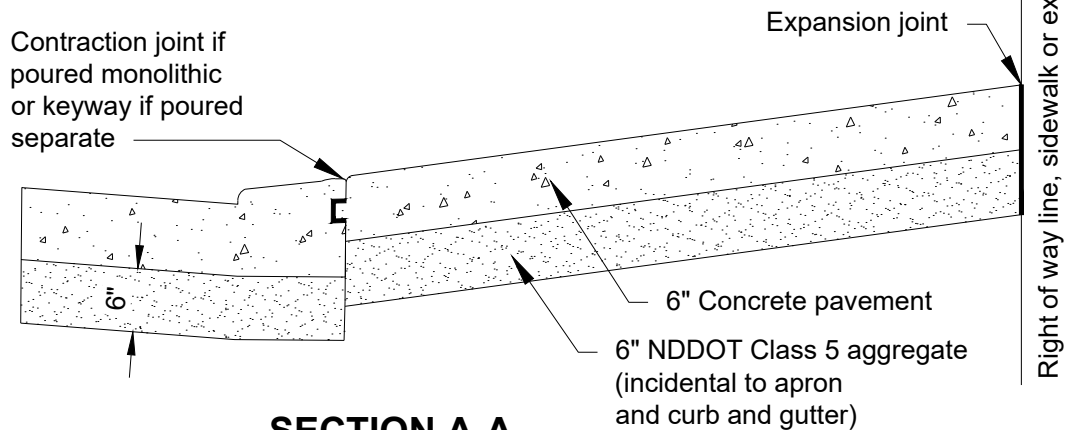

SECTION A-A

City Plate No.:
STR-11B
Last Revision:
6/17/2019
File:
STR_11B.dwg

STANDARD DETAILS CONCRETE DRIVEWAY APRON BOULEVARD 1.5 FT TO 4 FT

City of Minot
Engineering Department