

Remove concrete for driveway construction where required.

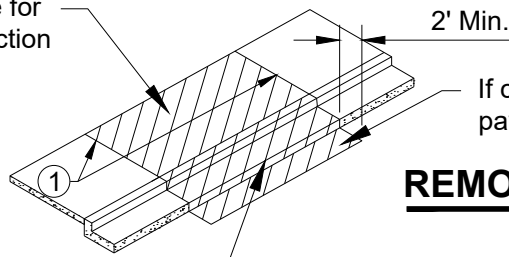

If curb cannot be removed clean, sawcut pavement and patch per section

**REMOVALS**

Remove curb and gutter. Entire curb and gutter section shall be removed prior to driveway construction.

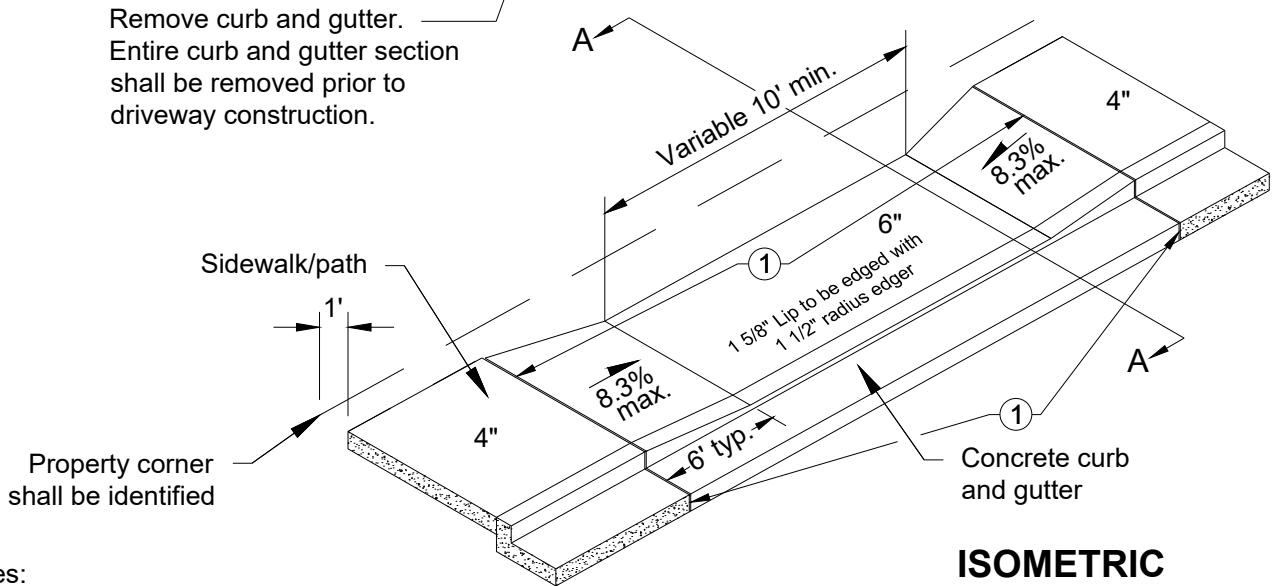

Property corner shall be identified

**ISOMETRIC**

**Notes:**

1. Where connecting to existing, saw to full depth and install expansion joint, or remove and replace curb and gutter to nearest expansion joint w/ two 1/2" x 24" smooth dowels.
2. Driveways greater than 10' wide shall have contraction joints perpendicular to curb with maximum 10' spacing. Match curb joints.
3. Forms are required on all edges.
4. All HMA patches shall be NDDOT FAA 43 HMA Pavement, PG 58S-28.
5. Max. cross-slope of sidewalk/path shall be 2% at all locations.

Contraction joint if poured monolithic or keyway if poured separate

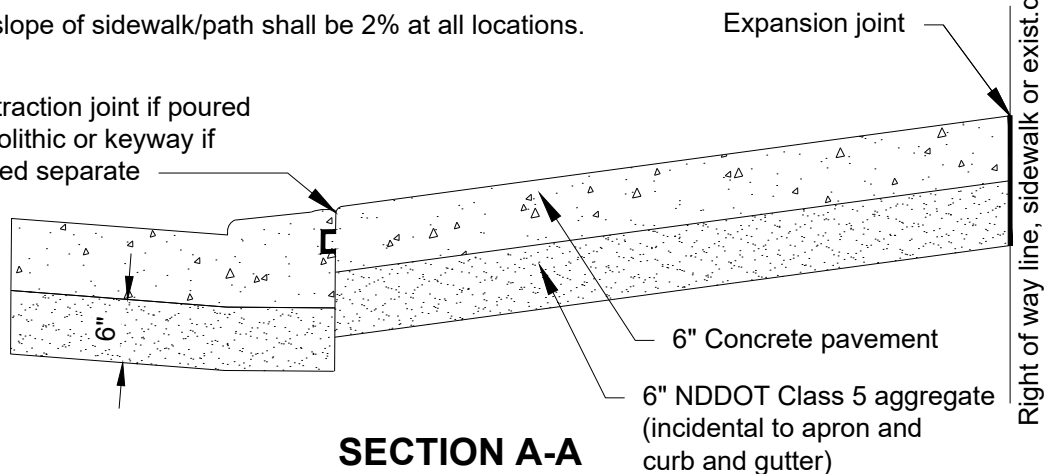

**SECTION A-A**

Expansion joint

6" Concrete pavement

6" NDDOT Class 5 aggregate (incidental to apron and curb and gutter)

Right of way line, sidewalk or exist. driveway

M:\STANDARD SPECS & DETAILS\2019\Detail Plates\STR-11A\_CONCRETE DRIVEWAY APRON BOULEVARD 0 TO 1.5FT.dwg

City Plate No.: STR-11A  
 Last Revision: 6/17/2019  
 File: STR\_11A.dwg

**STANDARD DETAILS  
 CONCRETE DRIVEWAY APRON  
 BOULEVARD 0 to 1.5 FT**

